

TITLE:

**INTRODUCTION OF
AIRDROME FITTING
PRODUCTS**



3251 AIRPORT WAY • LONG BEACH, CALIFORNIA 90806

AS (MS) and BAC Lt-Wt Flareless
“Inch & Metric” Separable Fittings

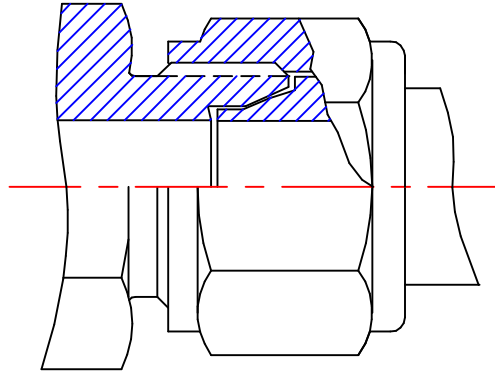

Materials:

- Titanium Alloy - 6AL-4V
- Cres - 304, 316, 321, 347 or 15-5 PH
- Alum Alloy - 2014-T6, 2024-T6 / T851 or 7075-T73

Qualification:

- Per PRI-QPL-AS18280-15.
- Per MIL-F-18280 military specification for “Inch” systems.
- Per AS4444 & AS18280 SAE specifications for “Inch” systems.
- Per BPS-F-125 Boeing specification for “Inch” systems.
- Per ISO7169 ISO specification for “Metric” systems.
- Per MA2005 SAE specification for “Metric” systems.

Approvals:

Airframe Approvals & Programs

- | | |
|------------------------|-------------------------------|
| AIDC | BD-100 |
| Bell | BA-609, Huey & Cobra upgrades |
| Boeing | B-xxx (all) |
| Boeing-Douglas | MD-xx (all) |
| Boeing-McDonnell | C-17 |
| Boeing-Hughes | AH-64 |
| Bombardier-Canadair | Challenger, Global Express |
| Bombardier-Canadair | BD-100 |
| Bombardier-DeHavilland | Learjet-45 |
| Bombardier-DeHavilland | DHC-8 |
| Bombardier-Lear | LearJet-45 |
| Bombardier-Shorts | LearJet-45 |
| Cessna | Citation |
| Gulfstream | GIV & GV |
| IAI | Galaxy |
| ILyushin | IL-96 (mm) |
| Lockheed | C-5 |
| Raytheon | B-xxxx |

Misc. Approvals & Programs

- | | |
|----------------|------------|
| Textron Marine | LCAC & C-7 |
| TRW | B-747 |